

Grit King® *Advanced Hydrodynamic Vortex Separator*

Removes up to 15 times more grit than conventional systems.

Applications

- New wastewater treatment plants.
- Retrofit to existing treatment works.
- Grit removal for potable water.
- Grit removal for sand and gravel extraction plants.
- Grit removal for industrial effluent.
- Filter media recovery.

Advantages

- No moving parts.
- No external power source.
- Highly efficient over a wide range of flows.
- Recovers clean grit.
- Minimal headloss.
- Small footprint.
- Low operating costs.
- Can be installed as a freestanding unit or in situ.

The Grit King® is an advanced hydrodynamic vortex separator that augments gravitational forces to separate grit from water. The Grit King® is an economical choice for new or existing municipal or industrial wastewater and water applications.

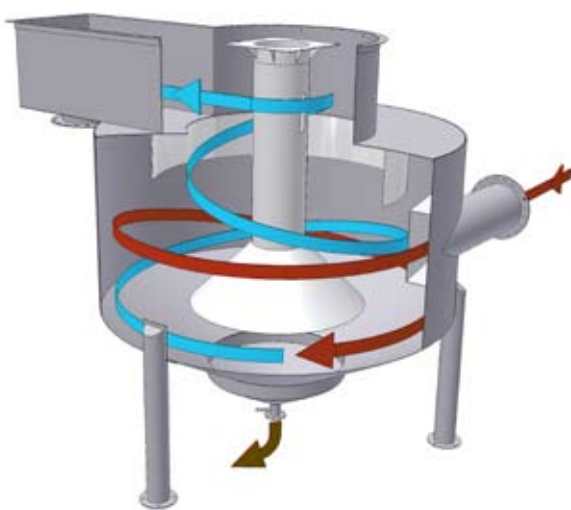
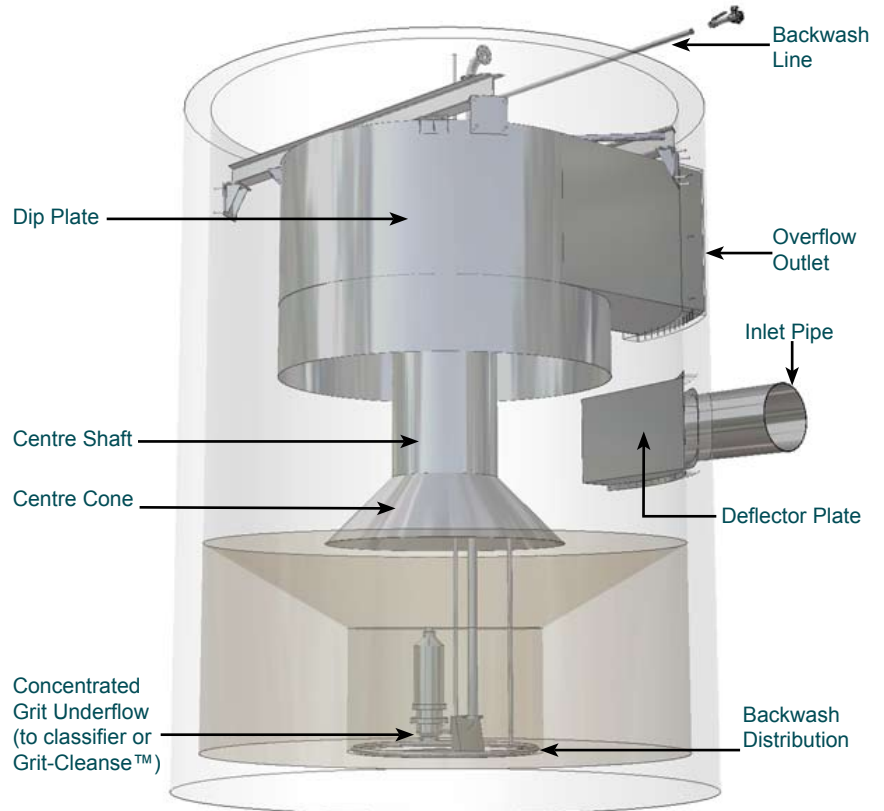

How it Works

- 1) Flow is introduced tangentially to the Grit King® via a tangential inlet causing a rotational flow path around the dip plate
- 2) The flow gradually spirals down the perimeter allowing the grit and sand particles to settle out by gravity (red arrow).
- 3) The grit collects in the grit pot as the centre cone directs flow away from the base and up around the centre shaft into the inside of the dip plate (blue arrow). The upward flow rotates at a slower velocity than the outer downward flow. The resulting 'shear' zone scrubs out the finer particles.
- 4) The concentrated grit underflow is pumped or gravity fed to a grit classifier for dewatering (brown arrow).
- 5) The result is clean dewatered grit with low organic content.



The Grit King® Process

The Grit King® Separator with Grit-Cleanse™

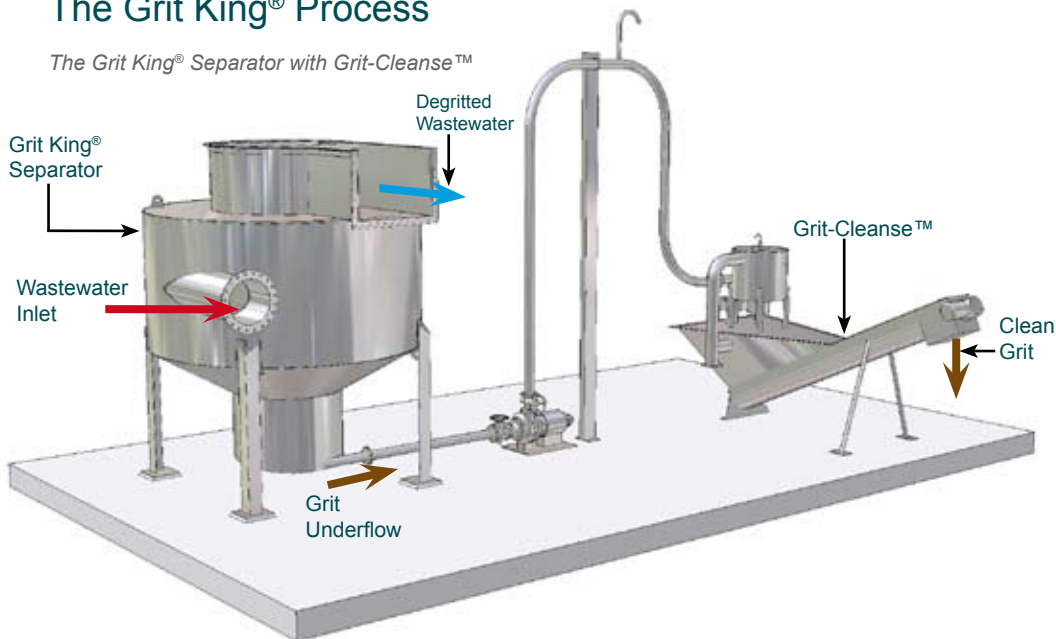

Configurations

The Grit King® Separator can be supplied as a freestanding unit in stainless steel or the specialised internal components can be mounted in a concrete chamber for below ground installation.

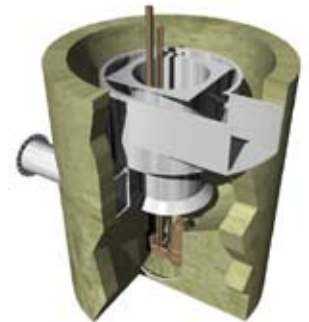

In Situ Grit King® Separator

Performance

- Typically sized to remove 95% of grit particles down to 200, 150 or 100 microns.
- Depending on site characteristics, moisture and faecal organic contents can be as low as 18% and 2% respectively when used with a secondary classification unit.
- Grit King® units can be designed for flow rates of 10 l/s to 1000 l/s per unit freestanding. For larger flows multiple freestanding units can be used or an insitu structure designed.
- Turndown ratios in excess of 10:1 can be accommodated when the Grit-Cleanse™ system is utilised.
- Multiple units can be used to accommodate large flow rates and provide additional flexibility.
- Headloss across the Grit King® is typically less than 150 mm.

Design Requirements

- Average Flow / DWF / Maximum Flow
- Full Flow to Treatment
- Particle Removal Efficiency
- Available Grit Loading
- Site Location Drawing



In Situ Grit King® Separator with Grit-Cleanse™



Freestanding Grit King® Separator with Grit-Cleanse™

turning water around ...®

This information is for guidance only and not intended to form part of a contract. Hydro International pursues a policy of continual development and reserves the right to amend specifications without prior notice. Equipment is patented in countries throughout the world.