

Hydro Vortex DropTM Shaft

Flow Control

Safer and less expensive than simple vortex drop shafts

APPLICATIONS

- Controlled drop of water into deep tunnels
- Energy dissipation of dropping water
- Flood control
- CSO systems
- Stormwater systems

ADVANTAGES

- No auxiliary air and/or maintenance shafts needed
- No requirement to keep an air core within the drop pipes so pipe sizes are significantly reduced
- Safe, controlled, efficient
- Self-activating with no moving parts
- A multiple pipe arrangement can accommodate higher flow rates
- Easy, safe and low maintenance

The **Hydro Vortex Drop Shaft** is a compact, single shaft system used for controlling flows from high level sewers into deep tunnels. The system dissipates the energy of dropping water in order to protect infrastructure from noise, vibration and damage.

Figure 1- Vortex Mode

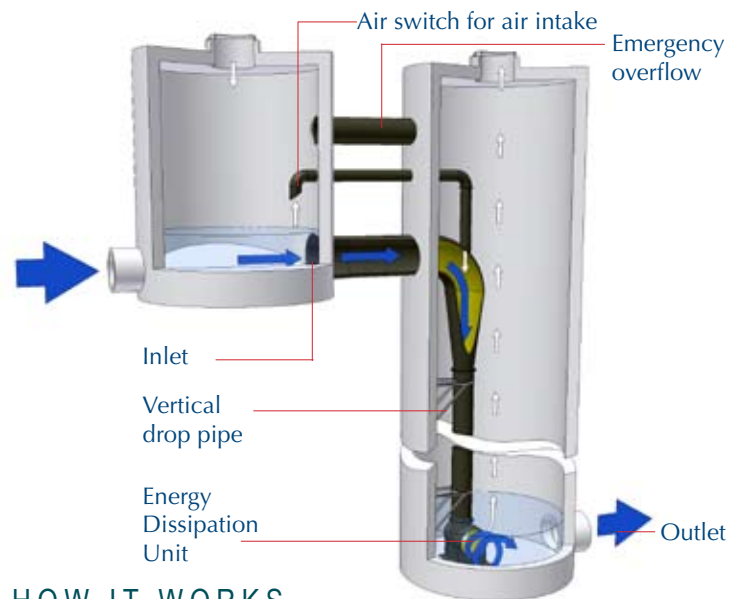
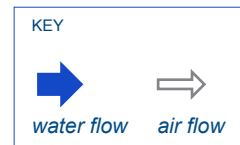

HOW IT WORKS

Vortex Mode

During low flow conditions, when the **Hydro Vortex Drop Shaft** is operating in the air-entrained mode, water flows into the inlet of the vertical drop barrel. Air enters the vertical pipe through the open air switch, located at a higher elevation than the inlet pipe. Water flows down through the vertical pipe barrel and into the cylindrically shaped Energy Dissipation Unit (EDU), where the geometry of the device causes water to flow in a horizontal vortex flow path through the cylinder and out to the outlet. The air core at the center of the vortex in the EDU throttles back and dissipates the energy of the flow that is conveyed down the vertical drop pipe. (Figure 1, top)

Pipe Full Mode

The combination of the vertical pipe and vortex in the EDU continues to throttle the effluent discharge as flows into the upstream chamber increase. As a result, the water level in the upstream chamber rises. As water levels rise, the Air Switch controls the amount of air that is allowed into the Vertical Drop Pipe. When the water level finally reaches the height of the Air Switch the air is switched off and the flow in the vertical drop pipe transitions into a pipe full mode of operation. The design of the air switch ensures a smooth transition preventing gugging noises and vibrations that can be caused by other drop shaft systems. (Figure2, left)

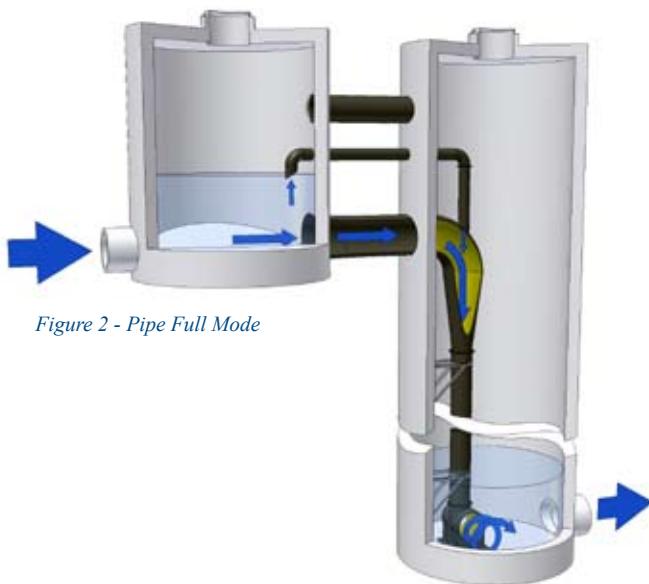

Maintenance Requirements

There are no moving parts and no replacement spares are required. The **Hydro Vortex Drop Shaft** is self-activating and is controlled by the hydraulics of the system.

The compact **Hydro Vortex Drop Shaft** is safer for operations and maintenance staff due to improved access and no requirement for auxiliary shafts.

Operator involvement should be no more than visual monitoring of the system to ensure that nothing unusual occurs. Systems can be designed with high level emergency overflow to accommodate instances when unpredicted surcharges are encountered at the bottom outflow.

Sizing

The **Hydro Vortex Drop Shaft** operates under pipe full conditions at design flows. Refer to the chart below for preliminary sizing guidelines.

There is no requirement to keep an air core within the drop pipes as in conventional designs, therefore pipe sizes are significantly reduced

Hydro Drop Shaft Sizing Chart

Flow Rate (MGD)	Item E (Ft.)	(Item B x Item D) (In.)
12	124	12 x 10
16	67	14 x 12
20	51	16 x 14
25	43	18 x 16
31	39	20 x 18
43	38	24 x 20
65	40	30 x 24
91	45	36 x 30
122	47	42 x 36
158	48	48 x 42
198	49	54 x 48
242	50	60 x 54

If your specific flow and drop conditions are not depicted in this chart please call our office.

For more information please call our office toll free at 800-848-2706 or inquire at www.hydro-international.biz.

Noise and Vibration

The **Hydro Vortex Drop Shaft** is designed to aid in the reduction of noise and vibration within the system because at design flows the system operates in pipe full conditions. This is a quieter mode of operation than conventional vortex drop systems. The **Hydro Vortex Drop Shaft** provides a smooth transition from the vortex mode to the pipe full mode, avoiding gugging noises and destructive vibrations caused by the system taking in large volumes of air.



KEY	
Item A	Connecting Pipe
Item B	Inlet Elbow
Item C	Custom Reducer
Item D	Drop Pipe
Item E	Overall Drop Height
Item F	Energy Dissipation Unit

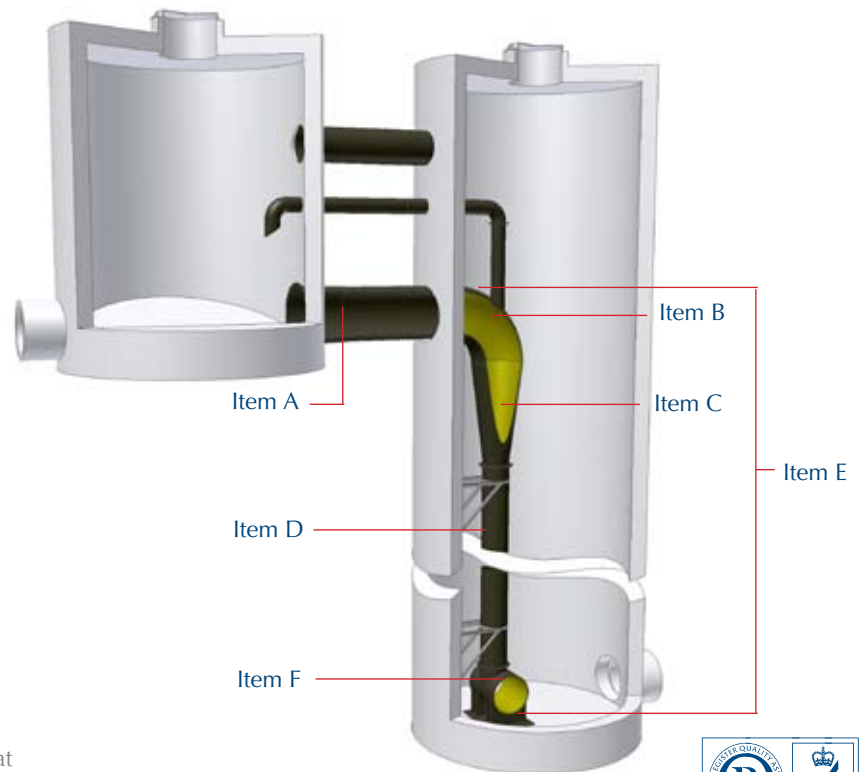

This information is subject to change without notice. Certificate No. 961366